

GWL/ Power Group Technology Solutions – Stay Powered for the Future

Product Development Report 2009/11/15



Real Time Battery Management System (RT-BMS)

The Real Time Battery Management System (RT-BMS) is an advanced battery management solution for any type of lithium-based cells. Unlike other management systems, the RT-BMS provides the battery management **during the complete charge and discharge cycle**. Each cell is managed **individually** and the **master control unit** manages the whole chain of cells.

If we consider a 100Ah traction battery with a cell capacity variance of $\pm 2.5\%$ being charged at 100A for 1 hour, a balancing current of up to 5A is needed, provided **balancing is enabled throughout the whole duration** of the charging cycle. Leaving the balancing only for the end of the charging cycle requires either a higher balancing current or a longer charging time. With a 200Ah battery, for example, a 10A balancing current is needed when charging at 200A, or a 2-hour charging time when charging at 100A.

The **RT-BMS solution** allows to manage each cell with **balancing currents up to 5A**. For example, operating large-capacity LiFeYPO₄ cells built into a 32-cells pack with a nominal voltage of 100V requires to release $\sim 640\text{W}$ of balancing energy ($= 5\text{A}$ [balancing current] \times $\sim 4\text{V}$ [cell voltage] \times 32 cells). Although this may seem to be quite a large amount of wasted power, a individual balancing of the cells at 5A **requires only $\sim 20\text{W}$ of energy** to be released from each managed cell.

The **RT-BMS** is designed according to the concept of single real-time balancers managing and balancing **up to 192 individual cells**. The individual cell-balancing units are controlled by the central **Master RT-BMS Control Unit**.

Real Time Battery Management System (RT-BMS) operating diagram

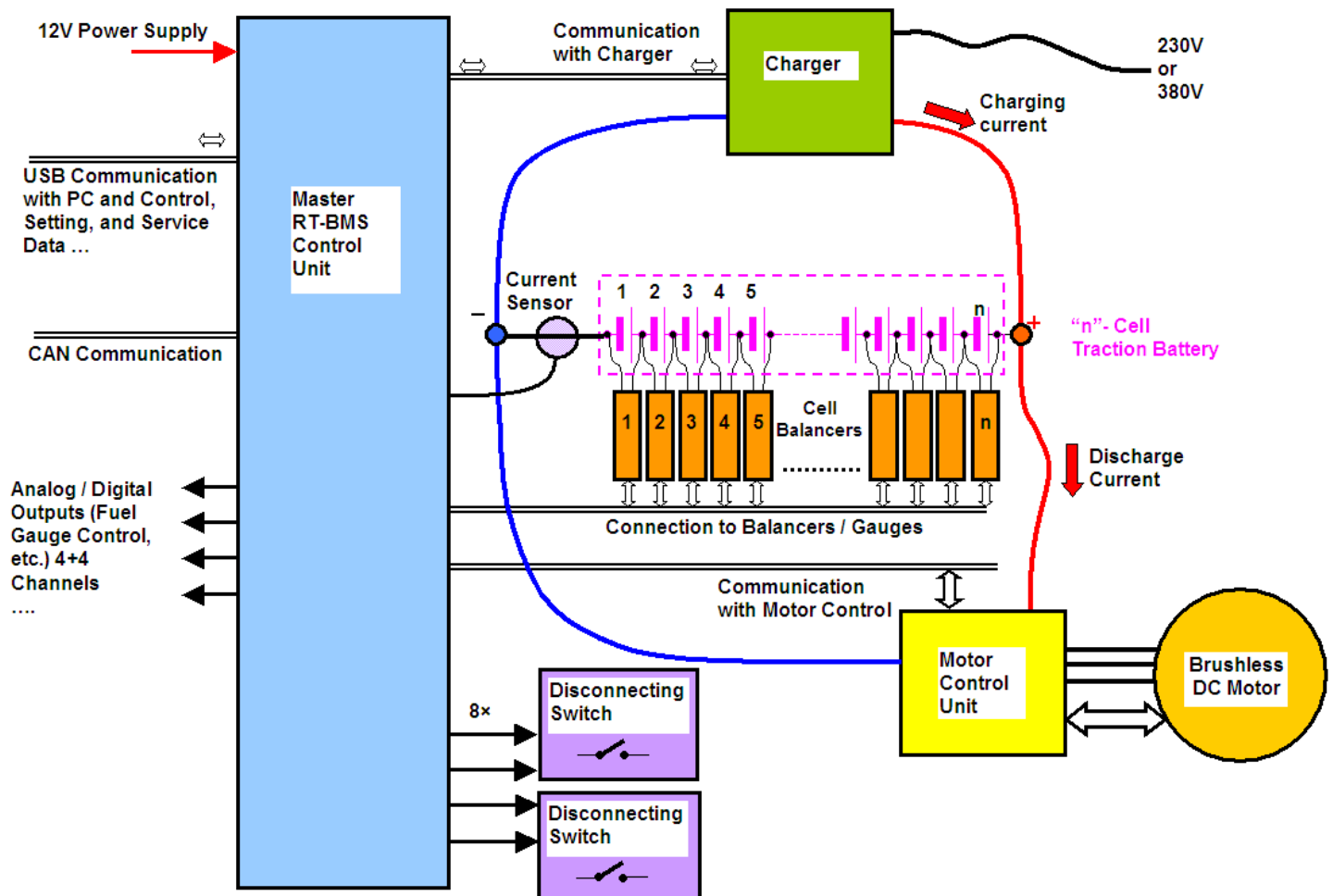

Besides controlling the cell balancers, the Master Control Unit of the RT-BMS is designed to provide for the **communication with the charger**, motor controller, and other devices, as well as **on-line transmitting of voltage levels**, cell temperature, charge and discharge current, and **signal data status** for user display.

The individual cell balancers are also used for data recording the battery discharge cycle. In the same way as while charging, during discharging the Master Control Unit monitors the status of each individual cell (temperature, voltage, internal resistance, total current, differences in relation to other cells, etc.). If user-defined **limits are exceeded, warning is signaled**. The Master Control Unit can also provide additional warnings of approaching conditions, such as a near-to-full discharge, over current, high temperature, etc. It can control the various indicators (remaining charge, drawn current, etc.) either on its own, or it can relay this information to other systems **via CAN data bus**—to displays or motor controllers, for example. The Master Unit also collects **stored data for later analysis**. It is also able to identify the damaged or defective cells, thereby preventing potential emergencies or failed discharges.

The whole RT-BMS system is compatible with **all current types of traction cells** (Pb, A123, LiPol, LiFe, LiFePO₄, LiFeYPO₄, etc.) – with the exception of the NiXX cells – i.e. all types of rechargeable cells with an operating **voltage between 2.7V and 5.0 Volts**.

The RT-BMS Master Control Unit is able **to communicate with a PC** (parameter settings, transfer of on-line or stored data) . The link is via galvanic-separated USB module.

The RT-BMS System Components Overview

Cell Balancing Unit (Module)

Dimension	81 × 60 mm
Weight	23 gram
Mounting to cooler	4× screw M3
Cell voltage (min. / max. values)	2.5 up to 5.0 V
Balancing current	0 up to 5 A
Sleep mode consumption	~10 µA
Operating mode consumption	~20 mA

Connectors: battery +, battery -, temperature sensor, 10-pin communication data lines to the Master Control Unit

Switch: module address setting (binary)

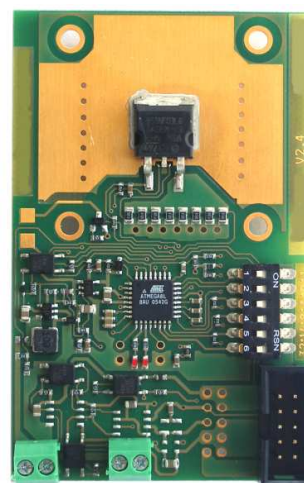

Master RT-BMS Control Unit

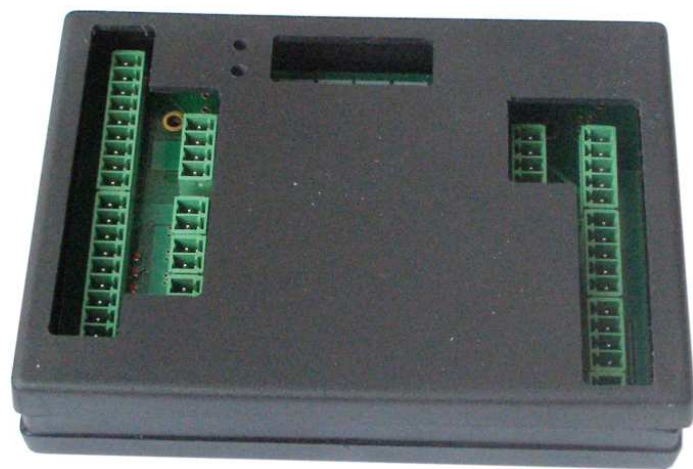

Dimension (plastic box)	130 × 95 × 25 mm
Weight (incl. box)	140 gram
Supply voltage	+12 V
Number of supported cells	max. 192 64 + 64 (+ 64)
Power control outputs	8 × 12 V/8 A
Signal Indication outputs	4 × 12 V/1 A
Auxiliary digital outputs	3 × 3.3V / 10V
Auxiliary frequency output	1 × 3.3V / 10V

<http://www.yttrium-power.com/>

GWL Europe Ltd., 2nd Floor, 3 Barclays Court Ave.
St Peter Port, Guernsey GY1 6AW, The Channel Islands,
Europe. **Email: info@gigawavelink.com**

Auto88 - EV & Power Solutions, c/o i4wifi a.s., Prumyslova 11, Praha 10, CZ-10219 Czech Rep., Europe Union
Email: auto88@auto88.cz, phone: +420 277 007 512 EU VAT ID: CZ27651851

The RT-BMS Components Connection to Electric Vehicle System

