

GWL/ Power Group Technology Solutions – Stay Powered for the Future

HZJ 200S-12V + auxiliary contact



Brief technical data

	Type and parameters	Coil & Rated voltage of contact circuit (V)								
		6	12	24	30	36	40	48	72	80
1	Coil power dissipation $\leq 15 (w)$, Max. Coil current (a)	0.95	0.8	0.3	0.25	0.2	0.18	0.21	0.1	0.08
2	Main contact rated current	Resistive load : $t=1ms, 200A$ Max. Rated permissible current to contact circuit for 4e.5 seconds								
3	Dielectric (volt) strength	50Hz 1000 V AC 1min								
4	operating time	Pickup (contact makes) $\leq 30ms$, release (contact breaks) $\leq 30ms$								
5	Action characteristic	Pickup (contact makes) $\leq 66\%Us$ Release (contact breaks) : $\leq 30\%Us, \leq 5\%Us$								
6	Mechanical life	300 thousand times								
7	Electric life	Resistive load ($t=1ms$) 50000 times inductive load (DC-5) : 60% Ie For resistive load 20000 times								

Configurational mounting diagram

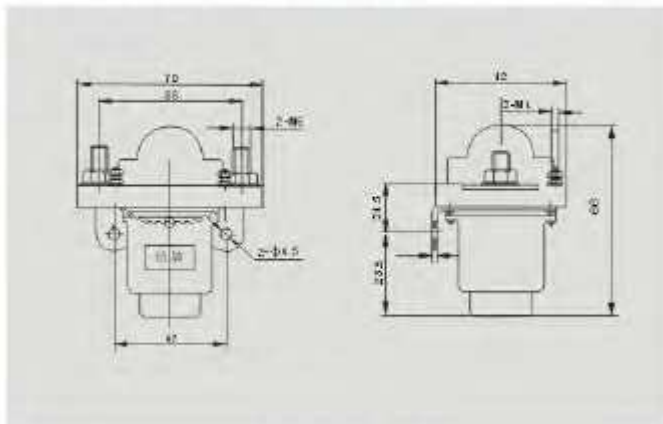

Circuit diagram

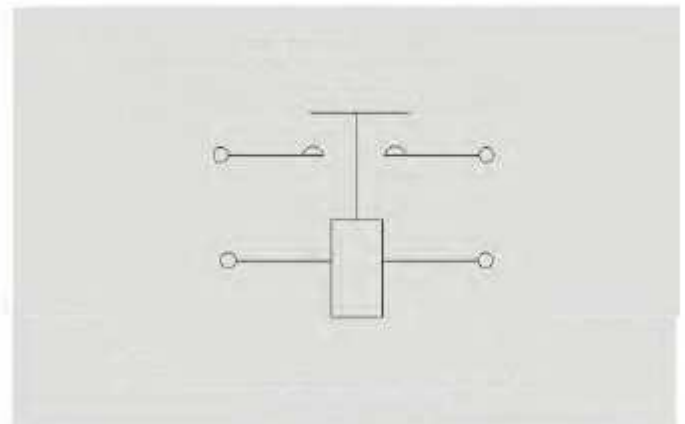

Environmental condition

- 1、 Ambient temperature : $-25 \sim +40^{\circ}C$
- 2、 Altitude range : 0-2000m
- 3、 Max. relative humidity 90% at $20^{\circ}C$
- 4、 Vibration : 10~50Hz, $10m/S^2$
- 5、 Shock resistance : $30m/S^2$
- 6、 Attitude : anywhere
- 7、 Power voltage fluctuating : $(0.7 \sim 1.1)Ue$
- 8、 Duty : 8h continuous

Nomination(nomogram)

