



LCD display E12
EVLED-CMS-E12

CONTENT

Content	1	Normal indication area	6
Introduction	2	Button definition	7
Overview drawing	3	Normal operation	7
Specifications	4	Error code definition	8
Functional overview	5		

- Name: Intelligent display
- Model: DPE12.UART
- Scope: EN15194 electrically power assistance cycle
- Appearance:



- Numbering on the back of the display
Numbers are divided into two lines (as shown in the figure):

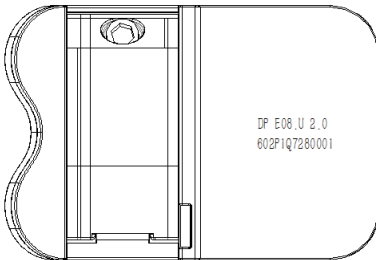

A. Up row number (as below)

DPE12.U 2.0

- ① DPE12.U : BAFANG display model
- ② 2.0: hardware version number

B. Down row number (as below)

602F8Q7280001

① 602: Wire length and connector model
850 M5.2

② F8: number of test device

③ Q7280001: Production date is
July 28th, 2016; SN is 0001

- Display P type wire label number rule
Number on the middle of P type label, number is divided into up row and down row and QR code is at right side (as shown in the below figure)



Content of QR code:

DPE12F80201.1

PD2526051205

DPE12.U 2.0

602F8Q7280001

The first line:

DPE12F80201.1 - Software version

The second line:

PD2526051205 - Parameter code

The last two lines:

DPE12.U 2.0 / 602F8Q7280001 - SN

SPECIFICATIO

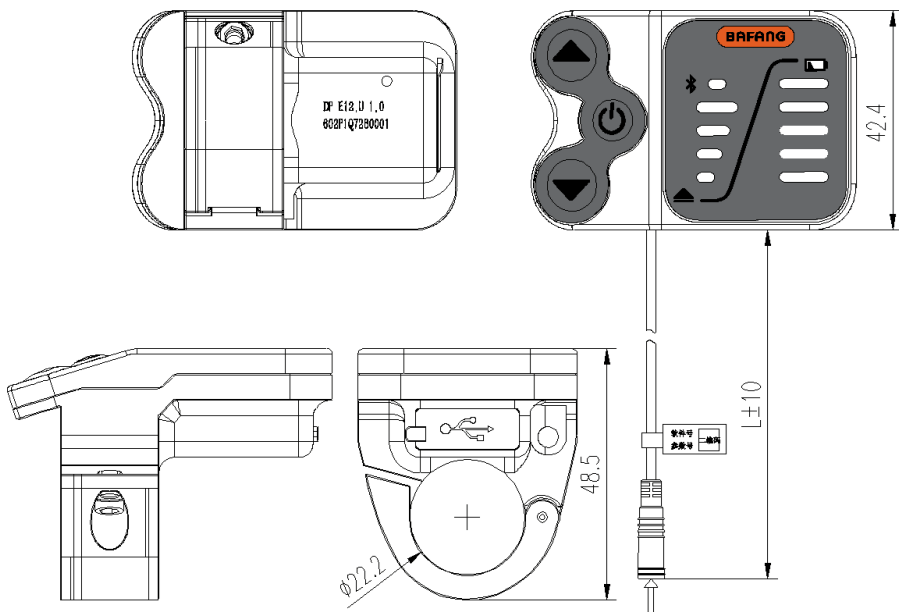

Housing material is ABS, decal material is PC with UV-Resistance.

OVERVIEW

- Rated voltage: 36V/43V/48V DC
- Rated current: 35mA lines(as shown in the figure)
- Maximum working current: 35mA
- When power off, leak current is less than: 1uA
- Working current supplied to controller: 50mA
- Operation temperature: -20°C~45°C
- Storage temperature: -30°C~70°C
- IP level: IP65
- Storage humidity: 30%-70%

NORMAL INDICATION

- Using the bidirectional serial communication protocol and the three-key keypad enables users to operate the display with ease.
- Intelligent battery level indication: thanks to an optimization algorithm, a stable display of the battery level is ensured, and the problem of fluctuating battery level indications common to most displays is avoided.
- Lamp automatic control: automatic turn on/ off front and back lamps, when outside light changes.
- Display LED second level automatic adjustment: according to the change of outside light, adjust LED display luminance automatically, that solve the problem of dazzling display at night and indistinct display under the strong light common to most LED display in the market.
- PAS level control: 0/1/2/3/4/5
- Error code prompt
- Walk assistance
- Set parameters: via communication cable, may set parameters in PC including wheel diameter, speed limit and so on, please see specific parameter set description document.
- If no use within 5 minutes, system turn off automatically.
- USB port can provide power to external device and display support Bluetooth function.

FUNCTIONAL

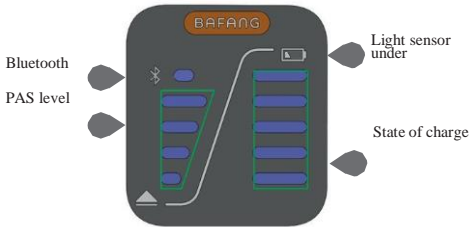

- State of charge indication: 5 LED display the state of charge, if the lowest LED flickers, it means the time to charge the battery.

LED indication definition (from down to up)	SOC
5	>75%
4	50%-75%
3	30%-50%
2	10%-30%
1	<10%
1 Flickers	≤5%



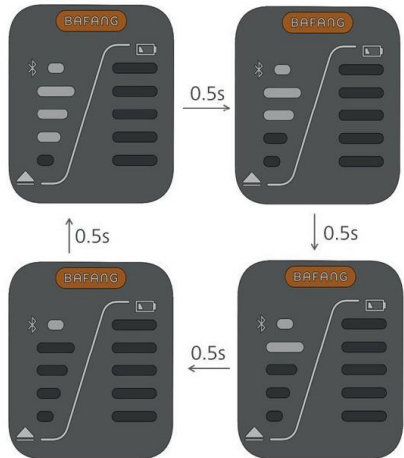



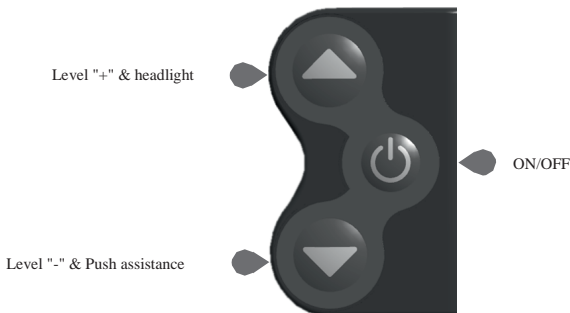

- PAS level indication: display current PAS level 0~4; if no LED display, it mean it is level 0; 1~4 is in accordance with the PAS level. In the mode of Push Assistance, LED loop light one by one from down to up with 0.5s time interval (as shown in the below figure)



ERROR CODE



NORMAL OPERATION

- Power on/off
press  for 2s, the display will turn ON;
press  for 2s, the display will turn OFF. It will automatically turn OFF when standby in 5 minutes.
- PAS level selection
Press  or  to switch between the different support levels (0 / 1 / 2 / 3 / 4 / 5); Lowest support level and the default level is 1; Highest level is 5; when no LED light, it is level 0 (mean park level).
- Lamp/LED display luminance
Press  for 2s, LED display turn dim, then turn on the front lamp and rear lamp at the same time. Again press  for 2s, LED display highlight, meanwhile turn off front light and rear light. (if fail to manipulate the lamps manually, need to restart the LED HMI and then lamps can restore automatically)
- Walk-assistance selection
Press  for 2 seconds, the walk assistance will be turned ON, and level LED flicker, If you move your finger away from this button, the walk-assistance will be turned OFF.
- Blue tooth connection
After the blue tooth is connected, the LED at the right of bluetooth  begin flicker.

BUTTON



This system can indicate all errors occurring on the Pedelec. In certain modes, the LEDs will flicker when an error code occurs.

Error code	Error definition	Solution
The second LED flickers 7 times in rapid succession	High voltage protection	Check the battery voltage
The second LED flickers 8 times in rapid succession	Fault with motor hall sensor inside	Have your dealer check the motor stator
The first LED flickers once	The motor temperature reaches to the max protection value	Stop riding and wait until the LED stop flickering
The first LED flickers once then the second LED flickers twice	Fault with current sensor inside controller	Have your dealer check the controller
The first LED flickers once then the second LED flickers 3 times	Fault with temperature sensor inside battery	Check the battery
The first LED flickers twice then the second LED flickers once	Fault with wheel speed detecting sensor	Check the motor stator
The first LED flickers twice then the second LED flickers twice	BMS communication fault	Replace the battery
The first LED flickers 3 times in rapid succession	Communication fault	<ol style="list-style-type: none"> 1. Check the connectors between the EB-BUS and the controller 2. Replace the control

Importer: GWL Power a.s., EU-VAT ID:
CZ25948253

www.evbike.cz